

INTRODUCTION TO VIDEO PRODUCTION

MOTION IS AN ILLUSION OF
STILL PICTURES, TAKEN IN
PARTICULAR WAYS,
PRESENTED FAST TO THE
VIEWER

HOW DOES THE ILLUSION WORK

HOW MANY PICTURES

HOW MANY PICTURES

FPS

HOW MANY PICTURES

FPS

ANYTHING SPECIAL ABOUT THE PICTURES ?

HOW MANY PICTURES

FPS

ANYTHING SPECIAL ABOUT THE PICTURES ?

YES

STILL PICTURES PRESENTED WITH FLICKER
RATE ABOVE 48 Hz ARE PERCIEVED
AS SMOOTH MOTION

FILM CAMERA TRANSPORT

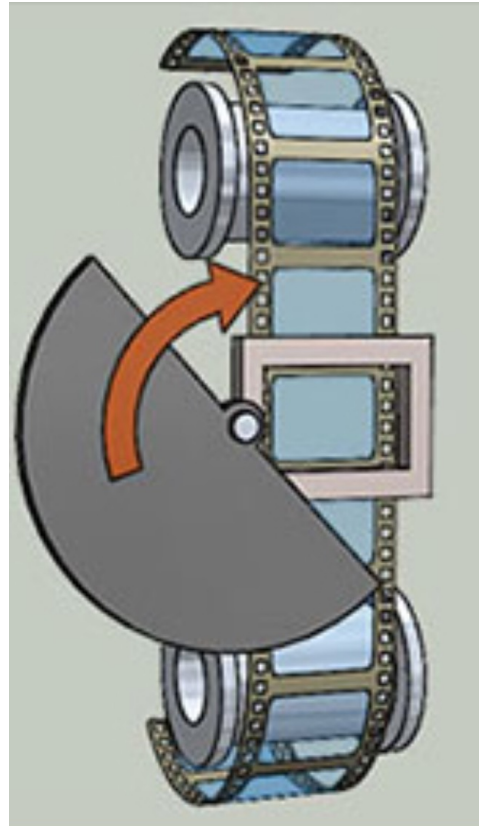

FILM PROJECTOR

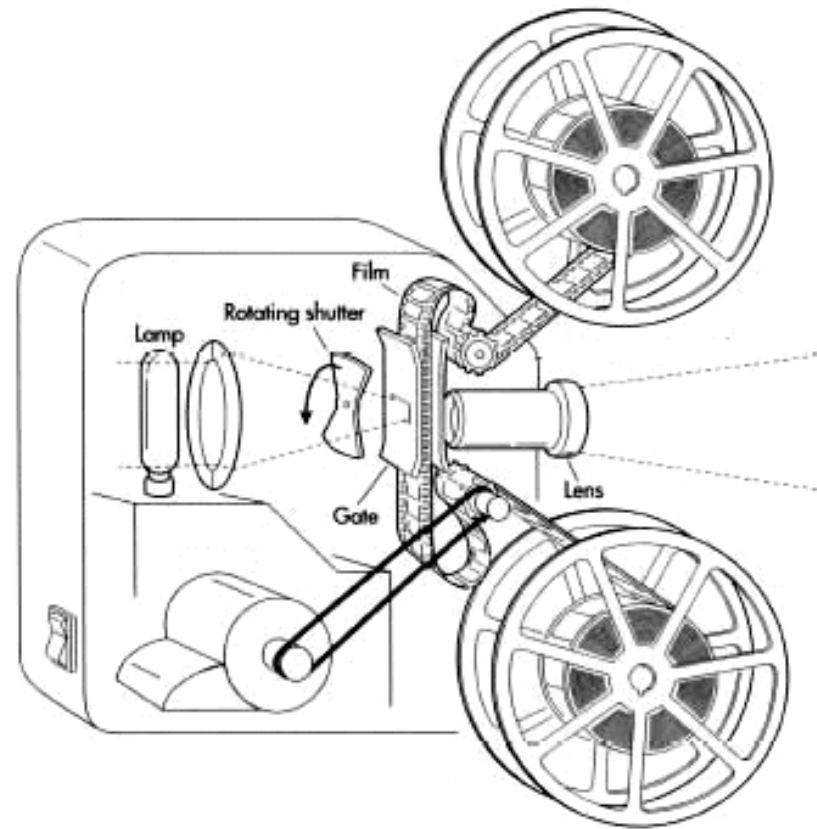

STILL IMAGES HAVE A MOTION BLUR
MATCHED WITH FRAME RATE

UNDERSTANDING MOTION BLUR
IS THE KEY TO SHOOTING
FILM OR VIDEO

MOTION BLUR



MOTION BLUR



MOTION BLUR

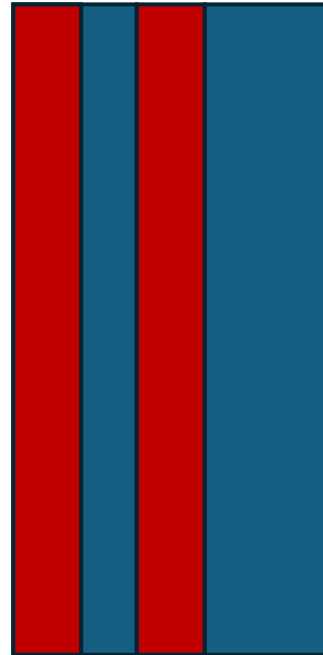

- PERCEIVED MOTION IS DEPENDENT ON
- FRAME RATE, SHUTTER SPEED AND CAMERA MOVEMENT

Why do we have the current
Frame rates used for film and video

Why 24fps

Why 24fps

- It was known that people perceived motion if the flicker rate was at least 48hz. However, at the time film reels were delivered to all the cinemas in the country for the launch of a new title. Very costly, so lowest frame rate was needed to reduce the amount of film to deliver. 24fps was about the limit for good sound then encoded on the film in an optical track.

Video

- Initially TV was an interlaced image at the mains frequency of the country. 60hz North America NTSC and 50hz PAL.

Video

- Initially TV was an interlaced image at the mains frequency of the country. 60hz North America NTSC and 50hz PAL.
- The camera would scan the odd lines top to bottom and then the even lines top to bottom. Reproduced by the CRT TV. This reduced the bandwidth needed to transmit the signal. First black and white, then colour. Again a technology solution to a financial problem

Video

- Initially TV was an interlaced image at the mains frequency of the country. 60hz North America NTSC and 50hz PAL.
- The camera would scan the odd lines top to bottom and then the even lines top to bottom. Reproduced by the CRT TV. This reduced the bandwidth needed to transmit the signal. First black and white, then colour. Again a technology solution to a financial problem.
- Because each field was half a frame the sequence was only complete after both odd and even had been transmitted. Sequence was called 60i but later revised to 30fps. To be correct they are 59.94 fields and 29.97fps. Also 29.97fps is not the same as 29.97P. The frame rate or time code reflected the interlaced sequence needed to sync the picture everywhere.

REVIEW OF HOW MOTION WORKS

- Frame rate needs flicker rate greater than 48
- Frame needs to have motion blur coinciding with frame rate.
- If image is too sharp it will still appear to judder even if it has flicker rate greater than 48.
- Solution is the 180 shutter rule essentially shutter is $1/2 \times \text{frame rate sec}$. So for 24fps film shutter is $1/48$ sec. For 60P shutter is $1/120$ sec. Faster shutter will result in sharper image and may destroy the illusion of motion. Image will judder.

SHOOTING VIDEO WITH MIRRORLESS CAMERA

Exposing for video

- SHUTTER SPEED IS LINKED TO FRAME RATE AND FIXED

Exposing for video

- SHUTTER SPEED IS LINKED TO FRAME RATE AND FIXED
- EXPOSURE IS SET BY ISO, APERTURE OR VND

Exposing for video

- SHUTTER SPEED IS LINKED TO FRAME RATE AND FIXED
- EXPOSURE IS SET BY ISO, APERTURE OR VND
- SINCE SHUTTER SPEEDS ARE LOW CAMERA WILL NEED TO BE STABILIZED

Framing for video

Framing for video

- Framing is much the same as shooting a still other than action is taking place in the frame. Best to anticipate the action. So frame for what is going to happen to limit camera movement.

Framing for video

- Framing is much the same as shooting a still other than action is taking place in the frame. Best to anticipate the action. So frame for what is going to happen to limit camera movement.
- For fast action stay wide. For shots that do not move fill frame for impact. Best to shoot in higher resolution than the project for delivery. Say 3840x2160 and deliver 1920x1080. That way the image can be cropped to frame in editing.
- Be aware of judder or camera blur when panning.

STYLE OF VIDEO

STYLE OF VIDEO

- CINEMATIC OR FILM STYLE
- VIDEO OR TV STYLE

CINEMATIC

- 24FPS, SHUTTER CLOSE TO 1/48
- SHALLOW DEPTH OF FIELD, BOKEH, DISGUISE BACKGROUND JUDDER. EMPHASIZE FOCUS OF SCENE.
- LOW CAMERA MOTION, TEND TO FIXED CAMERA SHOTS WITH DIFFERENT FRAMING
- FULL FRAME REFERED SENSOR

TV STYLE

- FASTER FRAME RATE 60P, SHUTTER 1/120.
- LARGER DEPTH OF FIELD
- ZOOMS AND PANNING COMMON
- SMALLER SENSORS HAVE ADVANTAGE

SUMMARY

- ILLUSION WORKS BY LINKING FRAME RATE AND SHUTTER SPEED
- SHUTTER SPEED TOO FAST WILL JUDDER
- SHUTTER SPEED TOO SLOW WILL HAVE TOO MUCH BLUR
- SHOOTING VIDEO REQUIRES STABILIZATION
- EXPOSURE IN BRIGHT LIGHT WILL REQUIRE VND FILTERS
- NEED TO TELL STORY BY VARYING FRAMING

What to do when you have taken the video

- Most video will need trimming.
 - Cut out shots of your feet etc
 - Create a story from many shots.
 - Before you do any of this backup your files.
 - Use a working copy to edit.

What to do when you have taken the video

- Most video will need trimming.
 - Cut out shots of your feet etc
 - Create a story from many shots.
 - Before you do any of this backup your files.
 - Use a working copy to edit.
- This is called editing your video
 - Create story
 - Correct exposure and colour
 - Export to a required file format

Using Davinci Resolve

- Setting project parameters
- Adding media
- Creating timeline
- Editing and titles
- Colour correction
- Export

File Edit View History Bookmarks Tools Help

What's New in Firefox 148 NSC Home - Nepean Sailing Breaking News, Latest N (20,527 unread) - evansrd Blackmagic Design

www.blackmagicdesign.com

Products Resellers Support Developer Con Media Splice Forum Blackmagicdesign



Home Log In



Blackmagic Camera ProDock

New dock adds professional camera connections to iPhone 17 including genlock, timecode, HDMI out, audio, external disk recording and more!

\$325



www.blackmagicdesign.com/products/blackmagiccamera#prodock

New Blackmagic Design RAW 10K

File Edit View History Bookmarks Tools Help

What's New in Firefox 148 NSC Home - Nepean Sailing Breaking News, Latest N (20,527 unread) - evansrd Blackmagic Design

www.blackmagicdesign.com





Products Resellers Support Developer Con Media Splice Forum Blackmagicdesign

Home Log In

Blackmagic Camera ProDock

New dock adds professional camera connections to iPhone 17 including genlock, timecode, HDMI out, audio, external disk recording and more!

\$325



www.blackmagicdesign.com/products/blackmagiccamera#prodock

New Blackmagic Design RAW 10K

File Edit View History Bookmarks Tools Help

What's New in Firefox 148 x NSC Home - Nepean Sailing x Breaking News, Latest N... x (120,527 unread) - evansrd... x Support Center | Blackmagic | x

www.blackmagicdesign.com/support/family/davinci-resolve-and-fusion

Video News https://www.youtube... Computers Sailing Sking Medical Investments Auto Bicycles Clothing Stuff Dance Grandkids stuff

Products Resellers Support Developer Company Media Splice Forum Blackmagicdesign

Home Support Center Log In

Support Center















How can we help you?

Welcome to the Blackmagic Design support center. Here you will find the latest software updates, support notes, instruction manuals and all kinds of helpful information. If you need extra help, then please go to our community forums and connect with the incredible experience of the television industry.

Dwaine
DaVinci Specialist
United States

Select a Product Family

Search by model or keyword

 Professional Cameras	 DaVinci Resolve and Fusion Software	 ATEM Production Switcher	 Ultimate	 Disk Recorders	 Capture and Playback	 Cintel Scanner
 Standards Conversion	 Broadcast Color	 Monitoring	 Network Storage	 MultiView	 Routing and Distribution	 Streaming and Encoding

Latest Download

Software Update 12 Feb 2026
DaVinci Resolve 20.3.2
This software update adds new trim editor options for dynamic trimming, improved kerning for subtitles, and new colorspace and gamma options for Fujifilm camera footage. Technical support for the free version of DaVinci Resolve 20 is only available via the Blackmagic Design community forums. [Read more](#)

Mac OS Linux
Windows x86 Windows ARM

Software Update 12 Feb 2026
DaVinci Resolve Studio 20.3.2

Latest Support Notes

Instruction Manual 10 Feb 2026
DaVinci Resolve 20.3 Manual
The DaVinci Resolve 20.3 reference manual offers detailed operational information on how to use DaVinci Resolve for editing, color correction, visual effects, motion graphics, audio post production and finishing.

Download Mac OS, Windows & Linux

Instruction Manual 10 Feb 2026
Fusion 20.3 User Manual
The Fusion 20.3 instruction manual contains information on how to use Fusion Studio 20.3 to create visual effects, animation, paint, keying, compositing with both 2D and 3D

Latest News

 **Blackmagic Design** 11 Feb 2026
@Blackmagic_News
DaVinci Resolve 20.3.2 Update! Adds new trim editor options for dynamic trimming, improved kerning for subtitles, better magic mask caching and more! Download at <http://bmd.link/Ff7qg>.

 **Blackmagic Design** 17 Dec 2025
@Blackmagic_News
DaVinci Resolve 20.3.1 Update! Adds the ability to quickly search for effects in Chinese, Japanese and Korean, improved Fusion previews for transforms and merges, as well as improved stereoscopic 3D monitoring and more! Download now at <http://bmd.link/ea469v>.

www.blackmagicdesign.com/support/download/872e312fc365492dbb9af19c469e6102/Linux, compositing with both 2D and 3D

YouTube sites

Tom Wade. <https://www.youtube.com/watch?v=6JP-qFBjEuA>

Casey Faris. https://www.youtube.com/watch?v=3mo_vgKfYCU

Darren Mostyn. https://www.youtube.com/watch?v=g52gP_bR65E

Creative Video Tips. <https://www.youtube.com/watch?v=gGY-47HwD4w>